

# METRISO PRO

Analog Insulation, Low Resistance and Voltage Measurement Instrument

3-349-815-03  
1/9.14



## Overview of Included Features

<b>METRISO</b>	<b>PRO</b>
<b>Article number</b>	<b>M550R</b>
<b>Measurements:</b>	
<b>R<sub>INS</sub></b> <b>U = 50, 100, 250, 500, 1000 V</b>	✓
<b>R<sub>LO</sub></b> <b>0.17 ... 4 Ω</b>	✓
<b>U</b> <b>10 ... 1000 V</b>	✓
<b>Display Functions:</b>	
Scale illumination	✓
<b>Limit value LED</b> (green/red) for: additional acoustic signal, limit values per VDE 0100	R <sub>INS</sub> R <sub>LO</sub>
<b>Caution LED</b> <b>for dangerous contact voltage</b> – When switched off – For active test voltage	✓
<b>FUSE LED</b> For blown fuse	✓
Battery level display	✓
<b>Special Functions:</b>	
Discharge capacitive devices under test	✓
Safety shutdown (UBatt < 8 V)	✓
<b>Features:</b>	
Measuring category CAT II 1000 V / CAT III 600 V / CAT IV 300 V	✓
Test resistor: 10 MΩ	✓
Factory calibration certificate	✓

## Scope of Delivery

- 1 Insulation and resistance measuring instrument
- 1 Factory calibration certificate
- 1 Set of batteries (8 pieces in battery holder)
- 1 Carrying strap
- 1 Alligator clip
- 1 KS17-4 cable set
- 1 Condensed operating instructions
- 1 Supplement Safety Information
- Detailed operating instructions for download from our website at [www.gossenmetrawatt.com](http://www.gossenmetrawatt.com)

## Battery Compartment Lid and Location of the Fuses (housing bottom)

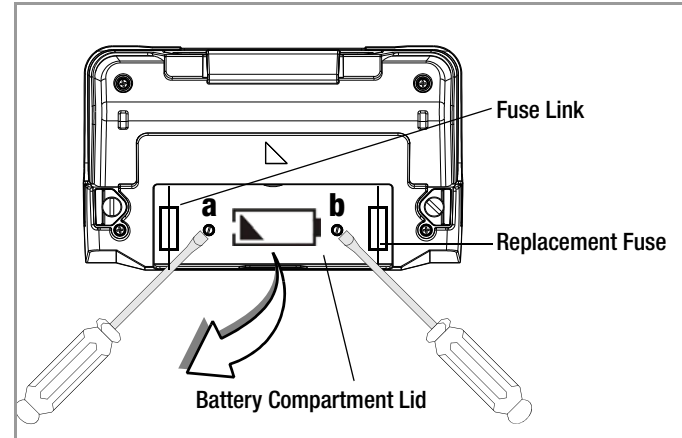

### Inserting the Battery Holder (side view)

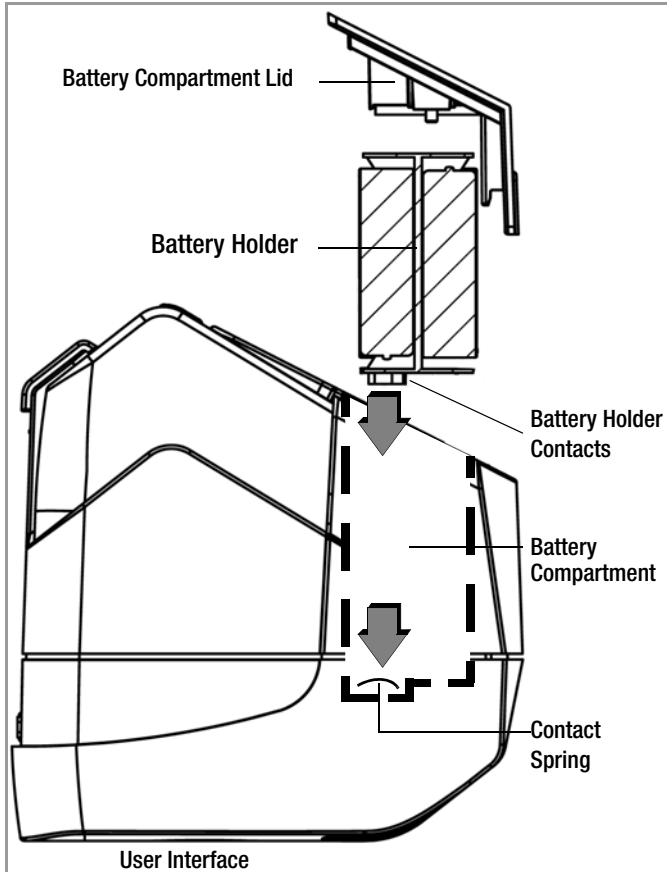

### Connections (housing top)

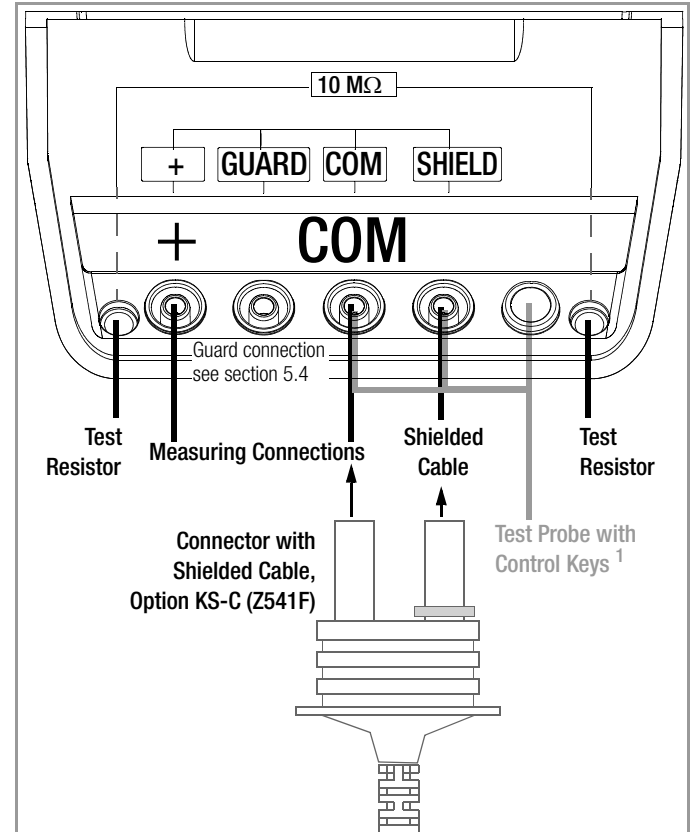

<sup>1</sup> Z550A accessory as option: test probe with measurement key and an additional key for illuminating the measuring point, including shielded, plug-in connector cable

## User Interface

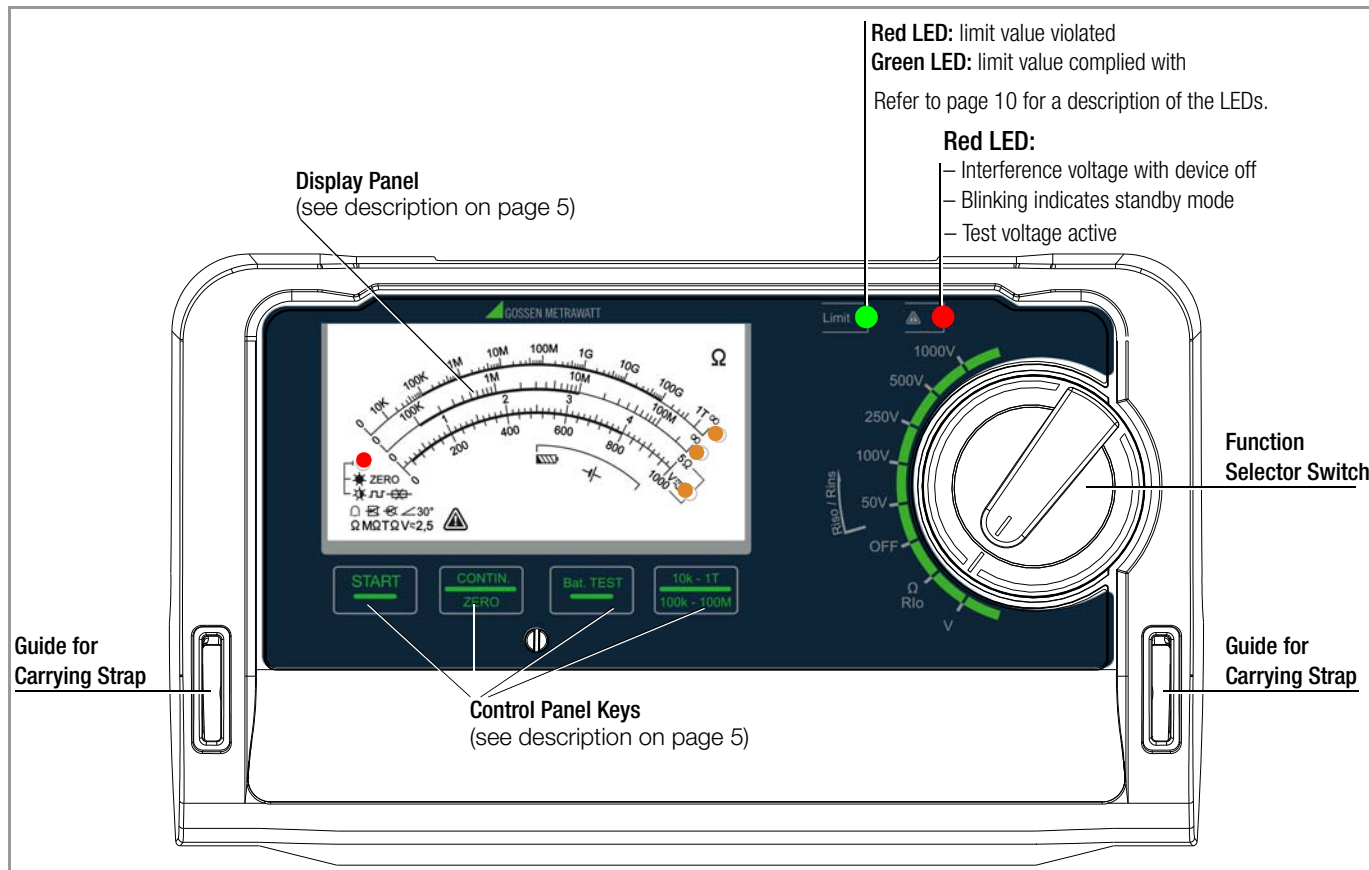

## Control Panel Keys – Adjusting Screw

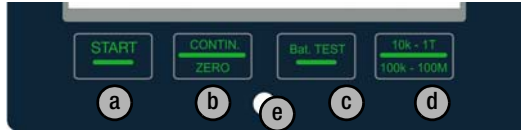

- a **START:** Starts insulation resistance measurement depending on rotary selector switch setting (see measuring ranges ① and ②), or low-resistance measurement with automatic polarity reversal (see low-resistance measuring range ③). Reactivates the instrument from the standby mode.
- b **CONTIN./ZERO \***  
Starts long-term measurement for insulation and low resistance (low resistance: polarity in one direction only). Each measurement takes up to 3 minutes; the instrument is then switched to standby. Reactivates the instrument from the standby mode.
- c **Bat. TEST:** Starts the battery test (see battery level display ⑤ and section 3.1).
- d **10k-1T/100k-100M**  
Switches between measuring ranges for insulation resistance measurement (see measuring ranges ① and ②), as well as section 5.2). Reactivates the instrument from the standby mode.

## Mechanical Zero Point – Adjusting Screw (e)

If necessary, use the adjusting screw (e) to set the pointer to the mechanical zero point (measuring range lower limit for all measuring ranges, except battery level indicator) with the switch in the **OFF** position.

## Electrical Zero Point – ZERO Function (Roffset)

**ZERO function (Roffset):** for subtracting cable resistance from the measurement results with the help of the **CONTIN.** and **10k-1T/100k-100M** keys (see section 7.3).

\* the supplementary labelling „ZERO“ depends on the product series

## Analog Display Symbols

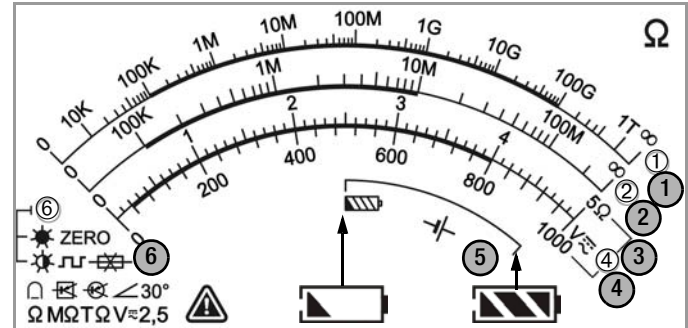

- 1 **Insulation resistance measuring range: 10 kΩ ... 1 TΩ**  
LED ① lights up orange: this measuring range is active  
LED ① blinks orange: open cable ends (special case with 50 V test voltage: full-scale pointer deflection of 1 GΩ)
- 2 **Insulation resistance measuring range: 100 kΩ ... 100 MΩ**  
LED ② lights up orange: this measuring range is active
- 3 **Low-resistance measuring range: 0 ... 5 Ω**  
LED ④ blinks orange if the range is exceeded
- 4 **Voltage measuring range: 0 ... 1000 V**  
LED ④ lights up orange: low-resistance measurement is active  
LED ④ lights up orange: voltage measurement is active
- 5 **Battery level indicator -|-**:  
*Left-hand range limit:* batteries low or weakly charged  
*Right-hand range limit:* batteries full or fully charged
- 6 **Fuse link and electronic fuse:**  
FUZE ZERO/FUZE ⑥ blinks red: blown fuse  
Voltage measurement is still possible.  
– **Funktion ZERO (Roffset):**  
LED ZERO/FUZE ⑥ lights up red permanently after offset blancing, see section 7.3.

Contents	Page	Contents	Page
1	7	10	23
2	8	11	24
3	9	11.1	24
3.1	9	11.2	24
3.2	9	11.2.1	24
4	10	11.2.2	25
4.1	10	11.3	25
4.2	11	12	26
5	12	13	26
5.1	12	13.1	26
5.2	12	13.2	29
5.3	14	13.3	30
5.4	14	13.4	31
6	15	14	31
7	16	15	32
7.1	17		
7.2	17		
7.3	18		
8	18		
9	19		

# 1 Applications

These instruments fulfill all requirements of applicable European and national EC directives. We confirm this with the CE mark. The relevant declaration of conformity can be obtained from GMC-I Messtechnik GmbH.

The METRISO PRO insulation and resistance measuring instrument allows for quick and efficient testing of protective measures in accordance with DIN VDE 0100, ÖVE-EN 1 (Austria), SEV 1000 (Switzerland), and regulations specific to other countries as well.

The device is equipped with a microprocessor and complies with IEC/EN 61557 / VDE 0413 regulations:

- Part 1: General requirements
- Part 2: Insulation resistance measuring instruments
- Part 4: Instruments for measuring resistance at earthing conductors, protective conductors and equipotential bonding
- Part 10: Combined measuring equipment for testing, measuring or monitoring protective measures

as well as requirements per VDE 0701-0702:  
Repair, modification and testing of electrical devices

## **The test instrument is especially well suited for:**

- Systems setup
- Initial start-up
- Periodic testing
- Troubleshooting in electrical systems

## **The following measurements and tests can be performed with the insulation measuring instruments:**

- Insulation Resistance
- Low-resistance
- Voltage

## **The following can also be tested by using a shielded measurement cable:**

- Floor covering electrostatic discharge capability

## 2 Safety Features and Precautions

The electronic measuring and test instrument is manufactured and tested in accordance with safety regulations IEC/EN 61010-1/VDE 0411-1 and EN 61557. When used for its intended purpose, safety of the operator, as well as that of the instrument, is assured.

**Read the operating instructions thoroughly and carefully before using your instrument. Follow all instructions contained therein.**

**The measuring and test instrument may not be placed into service:**

- If the battery compartment lid has been removed
- If external damage is apparent
- If connector cable or measuring adapters are damaged
- If the instrument no longer functions flawlessly
- After extraordinary damage due to transport
- After a long period of storage under unfavorable conditions (e.g. humidity, dust or extreme temperature)

### Opening of Equipment / Repair

The equipment may be opened only by authorized service personnel to ensure the safe and correct operation of the equipment and to keep the warranty valid.

Even original spare parts may be installed only by authorized service personnel.

In case the equipment was opened by unauthorized personnel, no warranty regarding personal safety, measurement accuracy, conformity with applicable safety measures or any consequential damage is granted by the manufacturer.

### Meanings of Symbols on the Instrument



Warning concerning a point of danger (attention, observe documentation!)



Protection class II device

CAT II / III

Device assigned to measuring category CAT II 1000 V / CAT III 600 V / CAT IV 300 V



EC mark of conformity



The device and included batteries may not be disposed of with the trash. Further information regarding the WEEE mark can be accessed on the Internet at [www.gossenmetrawatt.com](http://www.gossenmetrawatt.com) by entering the search term "WEEE".



## 3 Initial Start-Up

### 3.1 Battery Test

A battery test should be conducted after inserting the batteries, or if none of the measuring range LEDs lights up during insulation resistance measurement. Press and hold the **Bat. TEST** key to this end. Pointer deflection within the  $\pm$  scale for the battery test indicates the condition of the batteries with an average load amounting to a test voltage of 1000 V. The rotary selector switch position is not taken into consideration. The left-hand scale limit represents minimum required supply voltage, and the right-hand limit represent maximum available supply power.



#### Note

If the pointer is only deflected into the minimum supply power range, several measurements can still be executed with test voltages of less than 1000 V, because the battery test is conducted with a load which amounts to a test voltage of 1000 V.

The instrument does not function if the batteries have been depleted excessively, and alarm indication does not work either.

### 3.2 Installing or Replacing Batteries

New batteries must be inserted for initial start-up, or if only **minimal supply power is indicated**.



#### Attention!

Before opening the battery compartment (see page 5 for location), disconnect the instrument from the measuring circuit (mains) at all poles.

Eight 1.5 V size AA batteries in accordance with IEC LR 6 are required for operation of the insulation measuring instrument. Use new alkaline manganese batteries only.

Rechargeable NiCd or NiMH batteries may also be used. These can only be recharged externally. We recommend rechargeable NiMH batteries.

Always replace batteries in complete sets.

Dispose of batteries in an environmentally sound fashion.

- ⇨ Loosen both slotted screws for the battery compartment lid on the back, and remove the lid.
- ⇨ Remove the battery holder and insert eight 1.5 V size AA batteries with correct polarity in accordance with the symbols.



#### Attention!

Make sure that **all of the batteries are inserted with correct polarity**. If just one battery is inserted with reversed polarity, it will not be recognized by the instrument and may result in leakage from the batteries.

- ⇨ Push the battery holder into the battery compartment such that the battery holder's contacts touch the contact springs at the bottom of the battery compartment (see drawing on page 3). If the battery holder is not inserted as specified, the instrument cannot be supplied with power.
- ⇨ Replace the battery compartment lid and retighten the screws.



#### Attention!

The instrument may only be placed into service if the battery compartment lid is securely fastened!

## 4 General Operation

The test leads are connected to the “+” and “COM” jacks.

When measuring electrostatic discharge capacity for floor coverings, the shielded cable should also be connected to the **COM** and **SHIELD** jacks (KS-C accessory set, “cable set consisting of measurement cable and high-resistance measurement cable for measurements in the  $G\Omega$  range” (see diagram). Be sure to observe color coding.

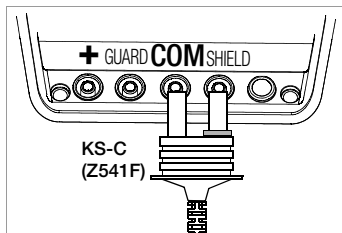

### 4.1 Switching On, Monitoring and Switching Off

The instrument is switched on as soon as the rotary switch is turned to any position other than **OFF**.

If battery voltage falls below the allowable limit value ( $U < 8\text{ V}$ ), the instrument cannot be switched on, or it is immediately switched off.

Measurement cannot be started in the resistance measuring ranges in the event of interference voltage.

The instrument is switched to the standby mode after 3 minutes, if neither the rotary switch nor any keys have been activated during this time.

A brief acoustic signal is generated before the instrument switches itself off automatically with the rotary switch in a position other than **OFF**. Moreover, 6 brief acoustic signals indicate every 10 minutes that the device is still on standby. The device should be switched off by setting the rotary selector switch to **OFF** in order to save (rechargeable) batteries.

The instrument can be activated once again by pressing the **START** key.



The instrument can be switched off manually by turning the rotary switch to the **OFF** position.

For purposes of transport and maintenance, we recommend turning the rotary selector switch to the **OFF** position in order to avoid switching the test instrument on inadvertently.

### Start-Up Test

When the instrument is switched on, i.e. as soon as the rotary switch is turned to any position other than **OFF**, all LEDs light up briefly: limit, caution, blown fuse, insulation resistance measuring ranges, voltage measurement and scale illumination.

### Optical Indicators

LED	Status	Function – Cause
	Limit Green	<b>Limit value indication</b> <ul style="list-style-type: none"> <li>– Measured <b>insulation resistance</b> does not violate the limit value.</li> <li>– Measured <b>low-resistance</b> <math>R_{lo}</math> does not violate the limit value.</li> </ul>
	Limit Red	<b>Limit value indication</b> <ul style="list-style-type: none"> <li>– Measured insulation resistance has fallen short of the limit value.</li> <li>– Measured low-resistance <math>R_{lo}</math> has exceeded the permissible limit value.</li> </ul>
	Red	<b>Detection of interference voltage in the off state</b> <sup>1</sup> If dangerous voltage of greater than 50 V is present at the measurement inputs: <ul style="list-style-type: none"> <li>– Initialization of the insulation resistance and low-resistance measurements is disabled.</li> <li>– Presence of test voltage is indicated.</li> </ul>

<sup>1</sup> Function testing should be executed at regular intervals (see following section regarding testing the LEDs).

## Testing the LED which Indicates Detection of Interference Voltage when Switched Off – OFF Switch Position

- Apply a voltage of greater than 50 V (+ and COM jacks).
- Turn the rotary switch to the V position.
- Read the voltage value at the analog display.
- Turn the rotary switch to the OFF position.

**Test results:** If applied voltage is unchanged and the LED which indicates the detection of interference voltage lights up red, the LED is OK. In this case, the LED reliably indicates interference voltage even when the instrument is switched off. We recommend executing this test at regular intervals.

## Limit Values for Insulation and Low-Resistance Measurements

Limit $R_{ISO} / R_{INS}$	50 k $\Omega$ @ $U_{ISO}/U_{INS} = 50$ V
	100 k $\Omega$ @ $U_{ISO}/U_{INS} = 100$ V
	500 k $\Omega$ @ $U_{ISO}/U_{INS} = 250$ V
	1 M $\Omega$ @ $U_{ISO}/U_{INS} = 500$ V
	1 M $\Omega$ @ $U_{ISO}/U_{INS} = 1000$ V
Limit $R_{LO}$	2 $\Omega$

## Limit LEDs for Insulation Resistance and Low-Resistance Measuring Ranges

The **Limit LED** lights up **green** if the measured insulation resistance value does not violate the limit value. The **Limit LED** lights up **red**, if the measured insulation resistance value violates the limit value. If the **Limit LED** does not light up at all, this means that the selected test voltage value has not been reached. A battery test is advisable in this case.

## 4.2 Analog Display

### Insulation Resistance Measuring Ranges

The logarithmic representation of the upper resistance scale allows for quick recognition of the order of magnitude. In order to achieve the required accuracy during protective measures testing, the **10k-1T/100k-100M** key makes it possible to switch to the expanded lower measuring range of 100 k $\Omega$  ... 100 M $\Omega$ .

The two **orange** LEDs, ① and ②, indicate which of the two resistance measuring ranges is active at the moment.

### Low-Resistance Measuring Range

**LED** ④ lights up orange to indicate that low-resistance measurement is active. **LED** ④ blinks when the measuring range is exceeded.

### Voltage Measuring Ranges

The two lower scales are for voltage measurement and the battery test (see section 3.1). **LED** ④ lights up orange in order to indicate that voltage measurement is active.

### Measuring Range Overflow in the Resistance Measuring Ranges

The LED assigned to the respective measuring range, namely ①, ② or ④ blinks orange in the event of measuring range overflow.

### Scale Illumination

Scale illumination is active for about 15 seconds after switching the instrument on, after a measurement is started and after changing measuring ranges.

## 5 Insulation Resistance Measurement – Riso/Rins Function

### 5.1 Connection



#### Note

##### Checking the Measurement Cables

Before performing insulation measurement, the test probes on the measurement cables should be short-circuited in order to assure that the instrument displays a value very close to 0  $\Omega$  (see section 7).

This makes it possible to detect interrupted measurement cables, which simulate high insulation resistance.

- ✦ Connect the device under test to the + and **COM** jacks.

Sample connection layouts for insulation resistance measurement are included in section 13.1.



#### Note

Insulation resistance can only be measured at voltage-free objects. The measurement cannot be started until the test probes are in contact with the device under test. If line voltage or interference voltage of greater than 50 V is applied to the measurement inputs, this is indicated by means of a double acoustic signal. Insulation measurement cannot be started as long as interference voltage is present.

### 5.2 Executing the Measurement

**Note:** Condensation must be ruled out when performing measurements at close to the freezing point.

- ✦ Select the measuring function, as well as the desired test voltage depending on the device under test, with the rotary switch, e.g.  $R_{iSO}$  100 V.



#### Attention!

Do not touch the instrument's terminal contacts or the conductive ends of the two test probes during insulation resistance measurement!

If nothing has been connected to the terminal contacts, or if a resistive load component has been connected for measurement, your body would be exposed to a maximum short-circuit current. The resulting electrical shock is not life endangering. However, the noticeable shock may lead to injury (e.g. resulting from a startled reaction etc.).

- ✦ Start an individual measurement by briefly pressing the **START** key, or initiate continuous measurement by briefly pressing the **CONTIN./ZERO** key.

- ✦ Contact the measuring point with both test probes.

A double acoustic signal indicates that measurement has been started.

The **Caution! LED**  remains illuminated for as long as test voltage is applied to the test probes.

LED ① lights up to indicate that the upper measuring range of 10 k $\Omega$  ... 1 T $\Omega$  has been complied with (default setting).

- ✦ Wait until the pointer settles in. Depending on the device under test, this may take anywhere from several seconds to half a minute if, for example, large capacitors (long cables) have to be charged.

- ✦ Read the measured value from the upper voltage scale ①.

If the **Limit** LED lights up green, the insulation measurement is valid and the limit value has not been violated.

If the limit value is fallen short of, the **Limit** LED lights up red.



### Note

If the Limit LED does not light up at all, this means that the selected test voltage value has not been reached. A battery test is advisable in this case (see section 3.1 on page 9).

### Switching to the Measuring Range with Higher Resolution

In order to perform measurement with the enhanced accuracy required for protective measures testing, select the measuring range with higher resolution, namely 100 k $\Omega$  ... 100 M $\Omega$ , with the help of the **10k-1T/100k-100M** key immediately after the measured value is displayed. LED ②, which is assigned to this measuring range, lights up.

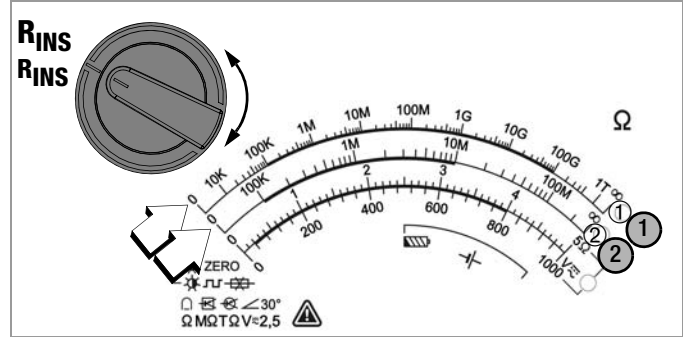
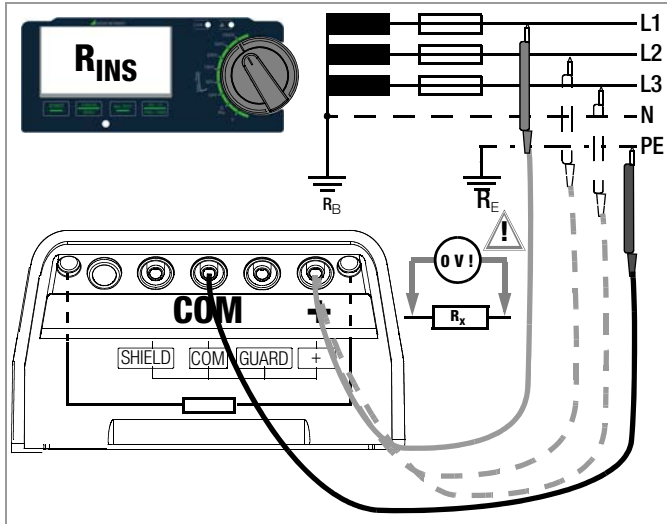

Read the measured value from the lower voltage scale ②.

If the **Limit LED** lights up green, the insulation measurement is valid and the limit value has not been violated. If the limit value is fallen short of, the **Limit LED** lights up red.

After test voltage is switched off – **Caution! LED** ⚠ goes out ( $U > 50 \text{ V}$ ) – the pointer remains frozen in place for about 3 seconds. When the **Limit LED** and the LED for measuring range ② both go out, the measurement has been completed and the pointer returns to its neutral position.



### Note

#### Three-Phase Systems

All conductors (L1, L2, L3 and N) must be tested against PE!



### Note

The instrument's batteries are exposed to excessive stress during insulation resistance measurement. For this reason, it's advisable to perform individual rather than continuous measurements.

## Special Case: Capacitive Devices Under Test



### Caution!

If measurement is performed at a capacitive object such as a long cable, it becomes charged with up to approximately 1000 V (test voltage)! Touching such objects is life endangering!

## 5.3 Ending the Measurement – Safe Discharging

**Individual measurement:** Measurement is ended automatically as soon as the measured value has settled in.

Continuous measurement is ended by once again briefly pressing the **CONTIN./ZERO** key.

When an insulation resistance measurement has been performed on a capacitive object it's automatically discharged by the instrument. Contact between the object and the instrument must nevertheless not be interrupted.

Do not disconnect until:

- The **Caution! LED** ⚠ (U > 50 V) is no longer illuminated.

As an alternative, the device under test can be discharged in a controlled manner (due to touch hazard) by switching to V and contacting the device under test until the **Caution! LED** ⚠ is no longer illuminated and the measuring movement indicates 0 V.

Do not reverse polarity while discharging, because internal surge protection will otherwise be triggered.

## 5.4 Measurements with the Guard Cable

The measurement of very high resistances necessitates extremely minimal measuring current and may be rendered problematic as a result of influences such as electromagnetic fields, humidity or surface pollution. An accurate test set-up is thus absolutely essential.

A guard cable must be used for measurements within a range of  $100\text{ G}\Omega$  ( $10\text{ G}\Omega$ ) ...  $1\text{ T}\Omega$ , in order to prevent surface current from distorting measurement results. The guard rings prevent current at the surface of the insulation material from flowing from the +measurement cable to the –measurement cable, instead of through the insulation material itself.

- Insert the plug from the guard cable into the appropriate jack in the test instrument.
- Plug the alligator clip onto the guard cable test probe.
- Connect the alligator clip to the guard ring between the two measuring points at the insulation material under test.
- Refer to section 5.2 on page 12 regarding the measuring sequence.

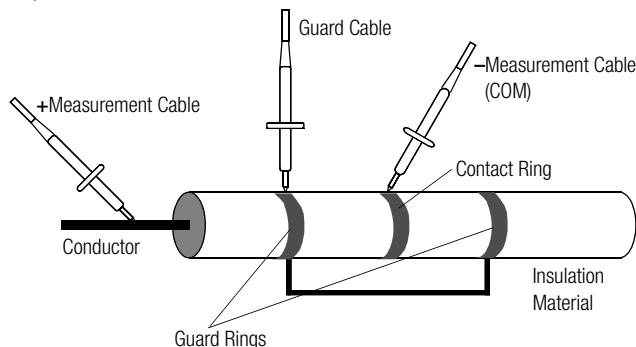

### Note

The following materials can be used as guard rings: aluminum foil, copper foil or metallic hose clamps.

## 6 Measuring Direct, Alternating and Pulsating Voltage – V Function

You can measure direct voltage, as well as sinusoidal alternating voltage with frequencies ranging from 45 to 65 Hz with this test instrument. Pointer deflection at the measuring instrument is always positive for the measurement of direct voltage, regardless of the polarity of the connections. Alternating voltage is always indicated as an RMS value.

Voltage measurement is used to test for the absence of voltage before performing the insulation resistance measurement, as well as for automatic discharging of capacitive devices under test. The falling voltage value can be observed at the display.

- Select the V measuring function with the rotary switch, LED ④ lights up permanently.
- Connect the measurement cables to the + and **COM** jacks.
- Contact the measuring point with both test probes.



### Attention!

A double acoustic signal is generated and the **Caution!** LED lights up red in order to indicate the presence of voltage of greater than 50 V.

- Read the measured value from the V scale. The measured value is displayed directly – without pressing the **START** key.
- After completing the measurement, switch the instrument off by turning the rotary switch to the **OFF** position.



### Note

No more than the maximum permissible voltage of 1000 V may be applied. Input impedance for the voltage measuring range is roughly 10 M $\Omega$ .

The **START** and **CONTIN./ZERO** keys have no function in this case.

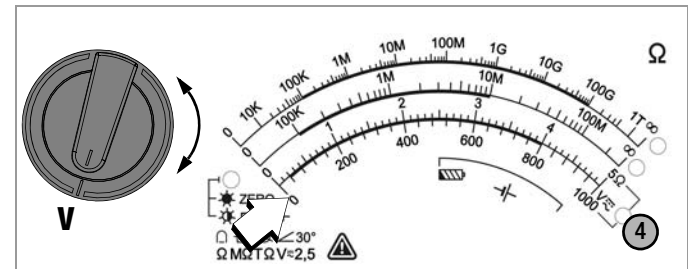
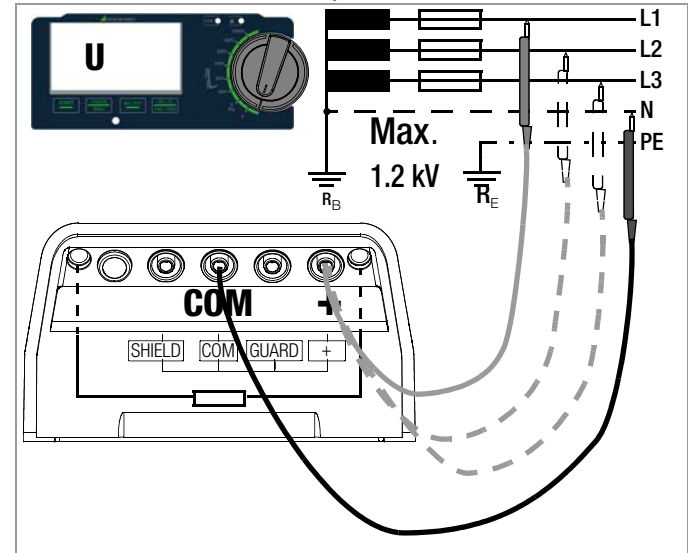

## 7 Measuring Low-Resistance of up to 5 Ω

### – R<sub>LO</sub> Function

According to the regulations, the measurement of low-resistance at protective conductors, earth conductors or equipotential bonding must be performed with (automatic) polarity reversal of the test voltage, or with current flow in one direction, and then in the other.



#### Attention!

In the measuring function R<sub>LO</sub>, measurements are performed with **currents higher than 200 mA**.

Please check before measuring whether your DUT or your circuit is designed for these high current values.

#### Connection



#### Note

Low-resistance can only be measured at voltage-free objects.

- Connect the device under test to the + and COM jacks.
- Select the **R<sub>lo</sub>** measuring function with the rotary switch.

**Attention:** The measurement cannot be started until the test probes are in contact with the device under test. If line voltage or interference voltage of greater than 50 V is applied to the measurement inputs, this is indicated by means of a double acoustic signal. Low-resistance measurement cannot be started as long as interference voltage is present. The display is not returned to low-resistance measurement until voltage is less than approximately 8 V. If resistance is greater than 5 Ω, LED ④ blinks.

#### Measurement Types

You can choose one of two different types of measurement:

- Measuring sequence with automatic polarity reversal (reversal of current flow direction) via the **START** key
- Manual measurement with positive polarity via the **CONTIN./ZERO** key

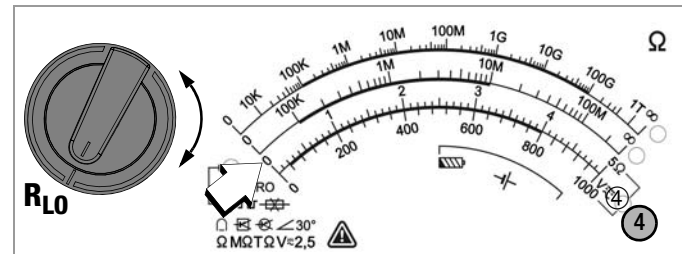
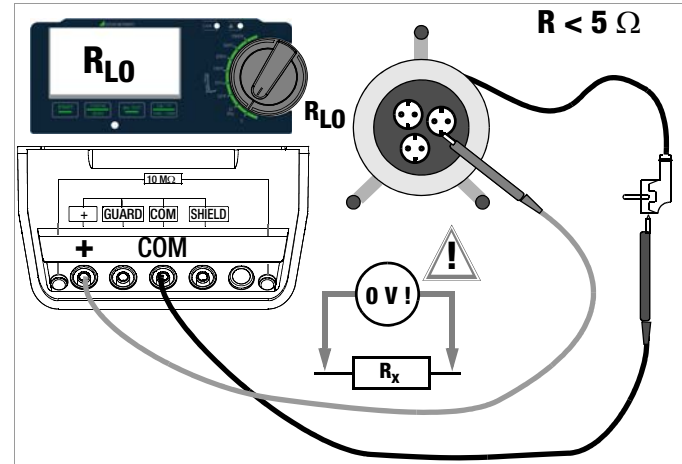



## 7.1 Measurement with Automatic Polarity Reversal

- ⇨ Start measurement in both current flow directions by briefly pressing the **START** key, the LED ④ lights up during measurement.

After the measuring sequence has been started, the instrument performs measurement with automatic polarity reversal, first with current flow in one direction ( $\Omega \rightarrow$ ), and then in the other ( $\leftarrow \Omega$ ). Measurement is executed in the background. During both measurements, the pointer briefly moves back towards 0  $\Omega$ , indicating to the user that measurement is being performed with both polarities in the background.

The respectively larger (worse) measured value is displayed when measurement has been completed (after the relay has audibly switched two times).

The **Limit LED** lights up in order to indicate that the measured value is valid. When the **Limit LED** and ④ go out, the measurement has been completed and the pointer returns to its neutral position.

### Limit Value Indication

If the measured value is less than or equal to 2  $\Omega$ , the **Limit LED** lights up green. If the measured value is greater than 2  $\Omega$ , the **Limit LED** lights up red.

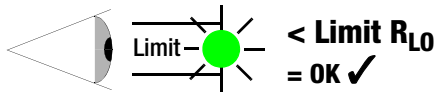

Resistances which do not demonstrate a stable value until after a “settling in period” should not be measured with automatic polarity reversal. In this case, measurement with automatic polarity reversal may lead to varying and/or inflated measurement values, and thus to an ambiguous reading.

## 7.2 Measurement with Manual Polarity Reversal

In order to determine whether or not test results are independent of current flow direction, measurement can be performed manually in one direction of current flow (positive polarity). Measurement in the other direction of current flow (negative polarity) is then conducted by switching the test probes.

- ⇨ Start continuous measurement by briefly pressing the **CONTIN./ZERO** key, the LED ④ lights up during measurement.

The red or green **Limit LED** indicates whether or not the limit value has been violated (see section 7.1).

Measurement takes up to 3 minutes, after which the instrument is switched to the standby mode. If you want to stop measurement prematurely, press the **CONTIN./ZERO** key once again, after which the relay switches audibly. Measurement is ended after roughly 5 seconds.

Differing results indicate voltage at the device under test (e.g. thermovoltage or unit voltages).

Measurement results can be distorted by parallel connected impedances in load current circuits and by equalizing current, especially in systems which make use of “overcurrent protection devices” (previous neutralization) without an isolated protective conductor. Resistances which change during measurement (e.g. inductance), or a poor contact, can also cause distorted measurements.

Examples of resistances whose values may change during measurement include:

- Incandescent lamp resistance with changing values caused by warming due to measuring current
- Resistances with a large inductive component

In order to assure unambiguous measurement results, causes of error must be located and eliminated.

### 7.3 Taking Measurement Cables and Extension Cables into Account (up to 5 Ω) – ZERO Function (Roffset)

Ohmic measurement cable resistance can be subtracted from the measurement results automatically. Proceed as follows:

- Select function **Rlo** with the rotary selector switch.
- Short circuit the test probes at the ends of the measurement cables.
- Press and hold the **CONTIN./ZERO** key.
- Additionally press the measuring range selection key (**10k–1T/100k–100M**) until the pointer indicates “0”.  
LED **ZERO/FUSE** © lights up red permanently:
- Release both keys.

During the course of subsequent low-resistance measurements, cable resistance  $R_{\text{Offset}}$  is taken into consideration, i.e. subtracted, as long as the rotary selector switch is not turned to the **OFF** position. Perform low-resistance measurement as described above in the preceding pages. The stored value is retained, even if the instrument has meanwhile been in standby operation provided that the rotary selector switch position has not been changed.

## 8 Test Resistor for Insulation Measurement for Checking the Insulation Measuring Instrument

According to section 5.3.1.2 of VDE 0105-100 (EN 50110-1), the following applies: “These measuring instruments must be tested before, and if applicable after use.”

The two outermost metallic jacks on the connection panel must be connected to each other internally via a 10 MΩ test resistor to this end.

The sum of test resistor and cable resistance (for both cables), including test probes, amounts to 10 MΩ ±5%. This value allows for quick self-testing.

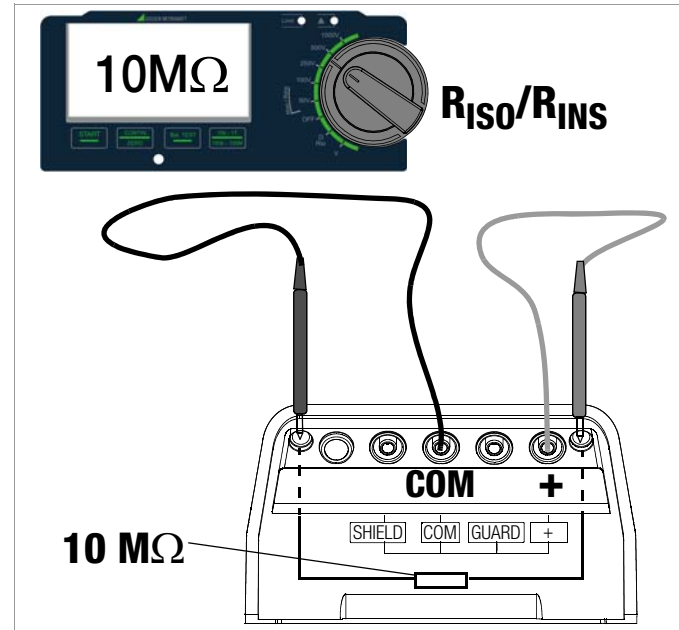

- Connect the measurement cables to the **+** and **COM** jacks.
- Insert the test probes into the above described metallic jacks.
- Select the  $R_{\text{ISO/INS}}$  measuring function with the rotary switch, as well as the desired test voltage, e.g.  $R_{\text{ISO}} 100 \text{ V}$ .
- Press the start key and view the measurement results.

The pointer should remain frozen at 10 MΩ for about 5 seconds. When the **Limit** LED and the LED for measuring range ① both go out, the measurement has been completed and the pointer returns to its neutral position.

## 9 Technical Data

Meas. Qty.	Scale / Standard	Measuring Range	Nominal Range of Use	Nominal / Open-Circuit Voltage	Nominal Current $I_N$	Short-Circuit Current $I_K$	Intrinsic Uncertainty under Reference Conditions <sup>2</sup>	Measuring Uncertainty <sup>3</sup>	Overload Capacity
$R_{INS}$	② VDE 0413	100 k $\Omega$ ... 100 M $\Omega$	100 k $\Omega$ ... 10 M $\Omega$	50 V /100 V: 1.25 $U_{ISO}$ 250 V /500 V / 1000 V: 1.1 $U_{ISO}$	1 mA	$\leq 5$ mA	$\pm 2.5\%$	$\pm 30\%$ of measured value	1000 V AC/DC TRMS
	①	10 k $\Omega$ ... 1 T $\Omega$	100 k $\Omega$ ... 100 G $\Omega$				$\pm 2.5\%$ <sup>1</sup>		
$R_{LO}$	③	0 ... 5 $\Omega$	0.17 ... 4 $\Omega$ <sup>4)</sup>	4 V < $U_0$ < 6 V	Test current $I_N \geq 200$ mA		$\pm 2.5\%$	$\pm 10\%$ <sup>5)</sup> of measured value	1000 V AC/DC TRMS
$U_{AC/DC}$	④	0 ... 1000 V	10 ... 1000 V	—	—	—	$\pm 2.5\%$	—	1000 V AC/DC TRMS
$U_{BAT}$	⑤	8 ... 12 V	8.5 ... 12 V	—	—	—	—	—	—

<sup>1</sup> Accuracy specified here is only achieved with the following optional accessory:

"shielded high-resistance measurement cable KS-C (article number Z541F)".

<sup>2</sup> Relative to scale length:

Scale 1: 83.13 mm

Scale 2: 75.05 mm

Scales 3 and 4: 67.02 mm

<sup>3</sup> Within the identified range on the respective scale (nominal range of use)

<sup>4)</sup> with ZERO balancing

<sup>5)</sup> 0.17 ... 2  $\Omega$ :  $\pm 20\%$

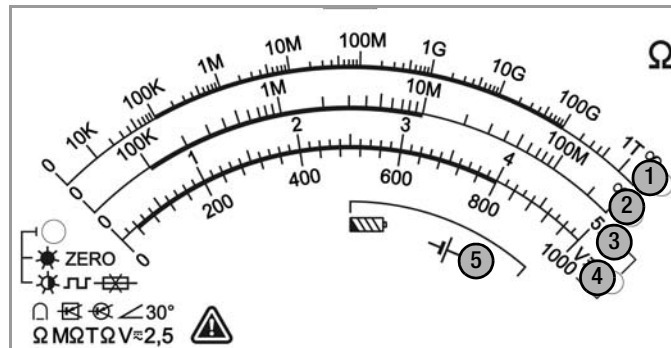

## Displays

Analog display

Measuring movement Moving-coil mechanism with core magnet

Scale length 83.13 mm (longest scale)

Limit LED LED lights up red to indicate an exceeded limit value. LED lights up green to indicate compliance with the limit value.



LED

LED lights up red to indicate the presence of interference voltage (when instrument is switched off), test voltage during insulation measurement or residual voltage after insulation testing ( $U > 50 \text{ V}$ )

Analog display LEDs Description see page 5

## Reference Conditions

Reference temperature  $+ 23 \text{ °C} \pm 3 \text{ K}$

Relative humidity 40 ... 75%

Measured quantity frequency 45 Hz ... 65 Hz

Measured quantity waveform Sine, deviation between TRMS and rectified value  $< 1\%$

Battery voltage  $9.5 \text{ V} \pm 0.1 \text{ V}$

Test resistor  $10 \text{ M}\Omega \pm 1\%$

Normal position of use  $30^\circ$

## Electrical Safety

Standard

VDE regulation VDE 0411, part 1, 1994-03

Protection class II

Pollution degree 2

Measuring category CAT II 1000 V / CAT III 600 V / CAT IV 300 V

Fuses

Fuse link FF315mA/1000V, effective in all resistance measuring ranges, 1 additional replacement fuse in the battery compartment

Electronic fuse for the protection of low-resistance measurement  $R_{LO}$

## Electromagnetic Compatibility (EMC)

Interference emission EN 61326-1:2006 class B

Interference immunity EN 61326-1:2006

## Power Supply

Batteries 8 ea. 1.5 V mignon cell (8 ea. size AA) (alkaline manganese per IEC LR14) or 8 rechargeable NiMH batteries (must be recharged externally)

Nominal range of use 8.5 ... 12 V

Battery test Battery capacity display via the Bat. TEST key

Battery saver circuit Standby function

Service life For  $R_{INS}$  (1000 V / 1 M $\Omega$ ) and  $R_{LO}$  with 20 s on-time and 1 measurement each for a duration of 5 s

– With batteries (alkaline manganese):

900 measurements

– With rechargeable batteries (2000 mAh):  
850 measurements

Safety shutdown If supply voltage is too low, the instrument is switched off, or cannot be switched on. When the rotary switch is set to the OFF position, the instrument is completely disconnected from the batteries (after approximately 10 seconds).

## Ambient Conditions

Accuracy temp. range	0 ... +40 °C
Operating temperature	-10 ... +50 °C
Storage temp. range	-25 ... +70 °C (without batteries)
Relative humidity	Up to 75% (max. 85% during storage/transport), no condensation allowed
Elevation	Max. 2000 m
Calibration interval	1 year (recommended)

## Mechanical Design

Dimensions	225 x 130 x 140 mm
Weight	Approx. 1.5 kg with batteries
Protection	Housing: IP 52, measurement cables and connectors: IP 40 per DIN VDE 0470, part 1 / EN 60529, housing category 2

### Excerpt from Table on the Meaning of IP Codes

IP XY (1 <sup>st</sup> digit X)	Protection Against Foreign Object Entry	IP XY (2 <sup>nd</sup> digit Y)	Protection Against Penetration by Water
2	≥ 12.5 mm dia.	2	Dripping (at 15° angle)
3	≥ 2.5 mm dia.	3	Spraying water
4	≥ 1.0 mm dia.	4	Splashing water
5	Dust protected	5	Jet-water
6	Dust-proof	6	Powerful water jets

## Display Values in Consideration of Measuring Uncertainty

Table for determining minimum display values for insulation resistance in consideration of the instrument's measuring uncertainty:

Limit Value	Minimum Display Value	Limit Value	Minimum Display Value
020 k $\Omega$	025 k $\Omega$		
100 k $\Omega$	111 k $\Omega$	100 M $\Omega$	111 M $\Omega$
200 k $\Omega$	219 k $\Omega$	200 M $\Omega$	219 M $\Omega$
500 k $\Omega$	541 k $\Omega$	500 M $\Omega$	541 M $\Omega$
0.20 M $\Omega$	0.25 M $\Omega$		
0.50 M $\Omega$	0.57 M $\Omega$		
1.00 M $\Omega$	1.11 M $\Omega$	1.00 G $\Omega$	1.11 G $\Omega$
2.00 M $\Omega$	2.19 M $\Omega$	2.00 G $\Omega$	2.19 G $\Omega$
5.00 M $\Omega$	5.41 M $\Omega$	5.00 G $\Omega$	5.41 G $\Omega$
10.0 M $\Omega$	11.1 M $\Omega$	10.0 G $\Omega$	11.1 G $\Omega$
20.0 M $\Omega$	21.9 M $\Omega$	20.0 G $\Omega$	22.6 G $\Omega$
50.0 M $\Omega$	54.1 M $\Omega$	50.0 G $\Omega$	55.9 G $\Omega$

Table for determining maximum display values for low-value resistance in consideration of the instrument's measuring uncertainty.

Limit Value	Maximum Display Value	Limit Value	Maximum Display Value
0.15 $\Omega$	0.11 $\Omega$		
0.20 $\Omega$	0.16 $\Omega$	5.00 $\Omega$	4.72 $\Omega$
0.50 $\Omega$	0.44 $\Omega$	10.0 $\Omega$	9.47 $\Omega$
1.00 $\Omega$	0.92 $\Omega$	20.0 $\Omega$	17.7 $\Omega$
2.00 $\Omega$	1.87 $\Omega$	50.0 $\Omega$	44.7 $\Omega$

## Voltage at Device Under Test During Insulation Resistance Measurement

Measuring voltage  $U_x$  at the device under test depending upon its resistance  $R_x$  at nominal voltage  $U_N = 50$  V, 100 V, 250 V, 500 V and 1000 V:

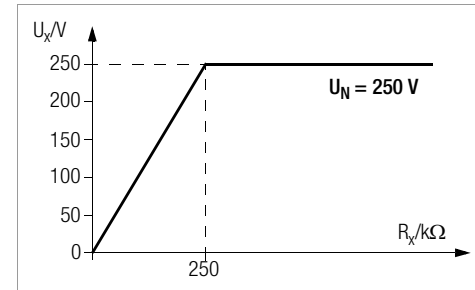
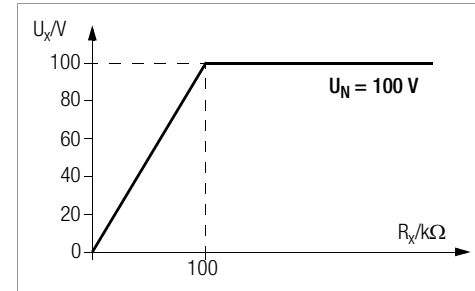

## 10 List of Abbreviations and their Meanings

### Voltage

- $U_{ISO}$  Test voltage or nominal voltage
- $U_{AC/DC}$  Measured voltage (sinusoidal alternating voltage)
- $U_{BAT}$  Operating voltage

### Current

- $I_N$  Nominal current (insulation resistance measurement)  
Test current (low-resistance measurement)
- $I_K$  Short-circuit current (insulation resistance measurement)

### Resistance

- LIMIT Limit value for insulation resistance or low-resistance
- Offset Correction value for measurement cable resistance
- $R_{ISO}$  Insulation resistance
- $R_{LO}$  Low-resistance (cable resistance)

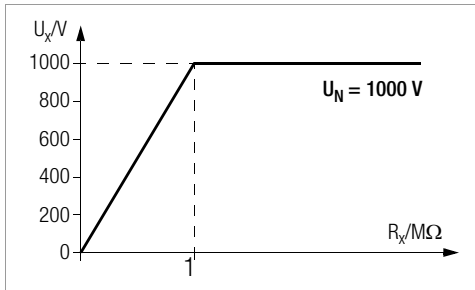
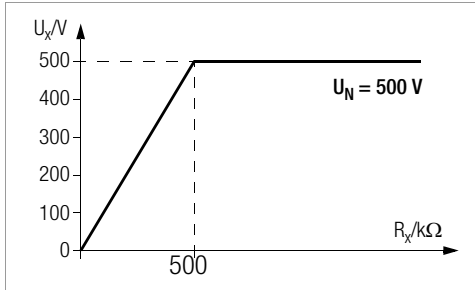

## 11 Maintenance

### 11.1 Battery and Rechargeable Battery Operation

When only one filled segment remains in the battery symbol, install a new set of batteries or charge the rechargeable batteries. Check to make sure that no leakage has occurred at batteries or rechargeable batteries at short, regular intervals, or after the instrument has been in storage for a lengthy period of time.



#### Note

We recommend removing the batteries during lengthy periods of non-use (e.g. vacation). This prevents excessive battery depletion or leakage, which may result in damage to the instrument under unfavorable conditions.

If leakage has occurred, the electrolyte must be carefully and completely removed with a damp cloth before installing new batteries.

### Replacing the Batteries

See section 3.2 and section 11.3.

### 11.2 Fuses

If a mechanical or electronic fuse has blown due to faulty operation or overload depending on the measuring function, the **ZERO/FUSE LED** blinks. The instrument's voltage measuring ranges are nevertheless still functional.

#### 11.2.1 Fuse Link – ZERO/FUSE LED

This fuse is active in all resistance measuring ranges except for voltage measurement. A replacement fuse is included in the battery compartment (FF315mA/1000V).



#### Attention!

Disconnect the instrument from the measuring circuit before opening the battery compartment lid in order to replace the fuse (refer to page 5 for location)!

### Checking the Fuse

If a resistance measuring range is selected with the rotary switch and measurement is started with a blown or defective fuse in the instrument, the **ZERO/FUSE LED** blinks. Prerequisite: The + and **COM** measurement jacks are not short circuited.

After eliminating the cause of error and replacing the defective fuse, the **ZERO/FUSE LED** goes out after the instrument has once again been switched on from rotary switch position **OFF**.



#### Attention!

Incorrect fuses may cause severe damage to the instrument.

Only original fuses from GMC-I Messtechnik GmbH assure the required protection by means of suitable blowing characteristics.

Short-circuiting of fuse terminals or the repair of fuses is prohibited!

The instrument may be damaged if fuses with incorrect ampere ratings, breaking capacities or blowing characteristics are used!



## Replacing the Fuse

- ⇨ Open the battery compartment lid by loosening the two screws.
- ⇨ Remove the blown fuse and insert a new one. A replacement fuse is included in the battery compartment.
- ⇨ Insert the new fuse.
- ⇨ Replace the battery compartment lid and retighten the screws.

### 11.2.2 Electronic Fuse – ZERO/FUSE LED

This fuse only protects low-resistance measurement (Rlo) from overloading (electronic hardware circuit).

As the electronic fuse blows faster than the mechanical fuse in the event of faulty operation of the instrument with live components, not only the instrument, but also the fuse link is protected in the low-resistance measuring range.

This means that, if interference voltage occurs during low-resistance measurement, the electronic fuse is blown. The measurement is aborted and the **ZERO/FUSE LED** blinks.

After eliminating the cause of error, the **ZERO/FUSE LED** goes out after the instrument has once again been switched on from rotary switch position **OFF**.

## 11.3 Housing

No special maintenance is required for the housing. Keep outside surfaces clean. Use a slightly dampened cloth or a plastic cleaner for cleaning. Avoid the use of cleansers, abrasives or solvents.

### Return and Environmentally Sound Disposal

The **instrument** is a category 9 product (monitoring and control instrument) in accordance with ElektroG (German electrical and electronic device law). This device is subject to the RoHS directive. Furthermore, we make reference to the fact that the current status in this regard can be accessed on the Internet at [www.gossenmetrawatt.com](http://www.gossenmetrawatt.com) by entering the search term WEEE.

We identify our electrical and electronic devices in accordance with WEEE 2012/19EU and ElektroG using the symbol shown at the right per DIN EN 50419.



These devices may not be disposed of with the trash.

Please contact our service department regarding the return of old devices (see address in section 14).

If the **(rechargeable) batteries** used in your instrument are depleted, they must be disposed of properly in accordance with valid national regulations.

Batteries may contain pollutants and heavy metals such as lead (Pb), cadmium (Cd) and mercury (Hg).

The symbol to the right indicates that batteries must not be disposed of with the trash, and must be brought to a designated collection point.



Pb Cd Hg

## 12 Recalibration

The measuring tasks performed with your instrument, and the stressing it's subjected to, influence aging of its components and may result in deviation from the specified levels of accuracy.

In the case of strict measuring accuracy requirements, as well as in the event of use at construction sites with frequent stress due to transport and considerable temperature fluctuation, we recommend a relatively short calibration interval of once per year. If your instrument is used primarily in the laboratory and indoors without considerable climatic or mechanical stressing, a calibration interval of once every 2 to 3 years is sufficient as a rule.

During recalibration at an accredited calibration laboratory (DIN EN ISO/IEC 17025), deviations from traceable standards demonstrated by your measuring instrument are documented. Ascertained deviations are used to correct display values during later use of the instrument.

We would be happy to perform DAkkS or factory calibration for you at our calibration laboratory. Further information is available at our website:

[www.gossenmetrawatt.com](http://www.gossenmetrawatt.com) (→ Company → DAkkS Calibration Center or → FAQs → Questions and Answers Regarding Calibration).

Recalibration of your instrument at regular intervals is essential for the fulfillment of requirements according to quality management systems per DIN EN ISO 9001.

\* Examination of the specification, as well as adjustment, are not included in calibration. However, in the case of our own products, any required adjustment is performed and adherence to the specification is confirmed.

## 13 Appendix

### 13.1 Sample Connection Layouts for Insulation Resistance Measurement

#### Insulation Resistance Measurement per DIN VDE 0100, Part 600

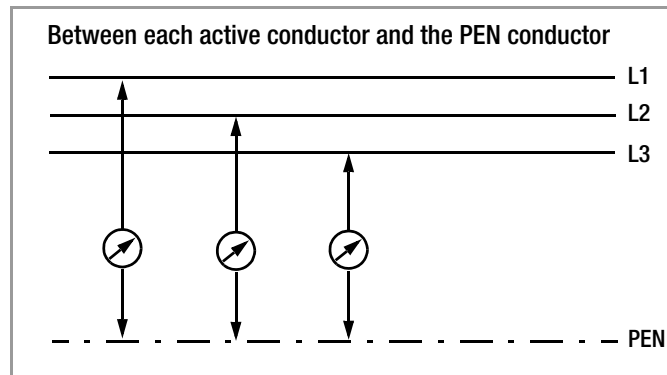
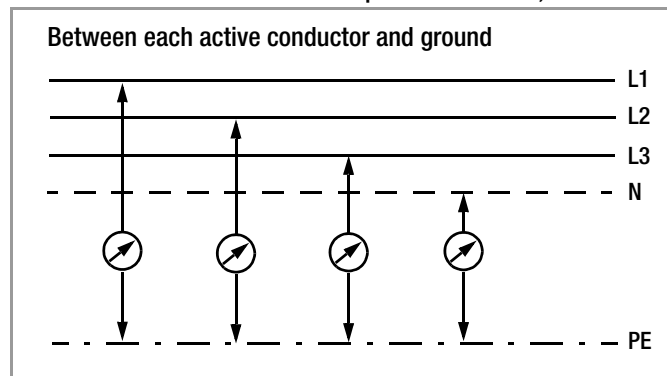

## Insulation Resistance Measurement in Different Types of Systems

Between each active conductor (phase and neutral conductors) and ground

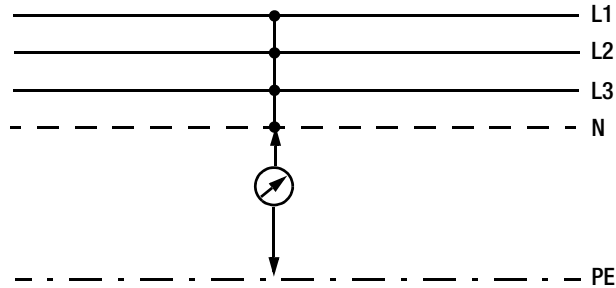

Between each active conductor and the PEN conductor

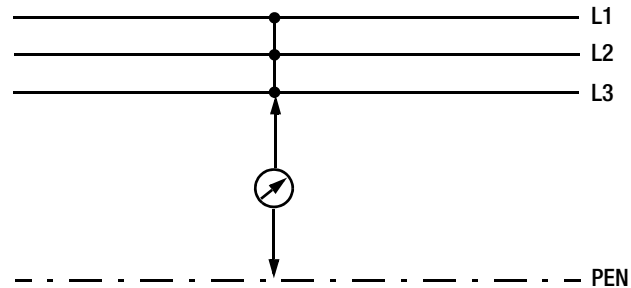

### TN-S

- With or without consumer
- N – PE, separately

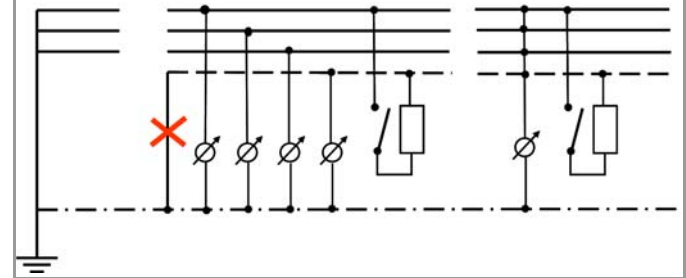

### TN-C

- With or without consumer
- N – PE, together

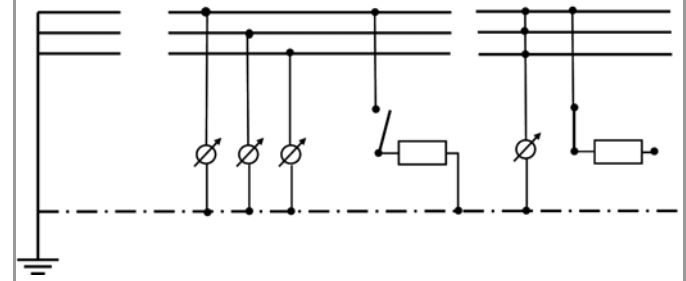

TT

- With or without consumer

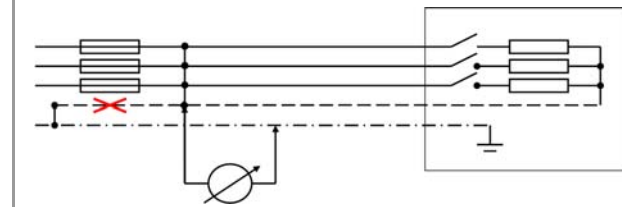
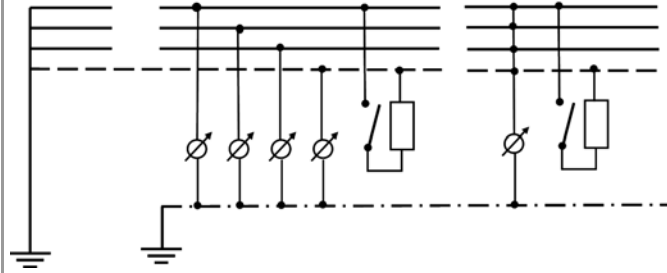

**Caution:**

- Open the overcurrent protective device.
- Disconnect the N conductor.
- Jumper the L and N conductors.
- Insulation measurement between L conductors and N to PE.

**3-phase current (switched at all poles)**



**In the distributor: individual and combined measurements**

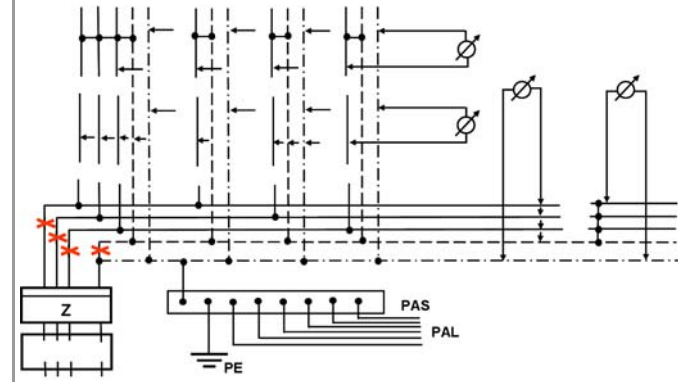

## 13.2 Attaching the Test Probe Holder to the Carrying Strap

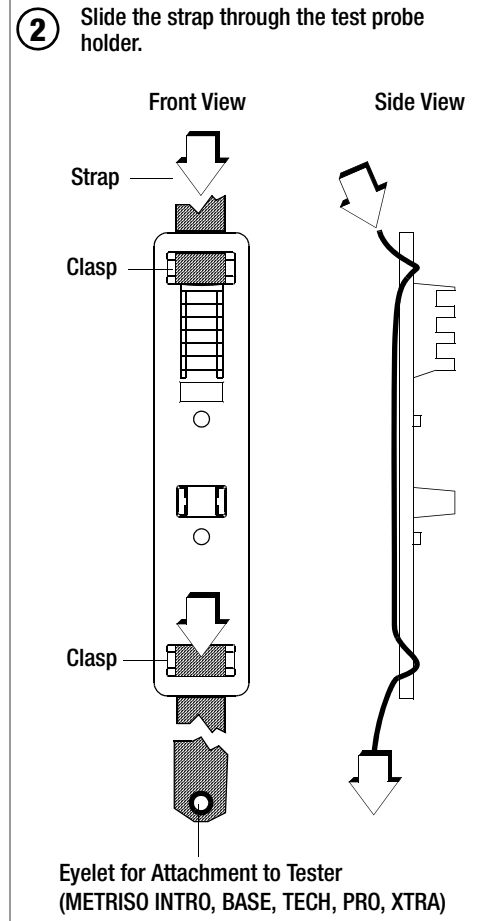
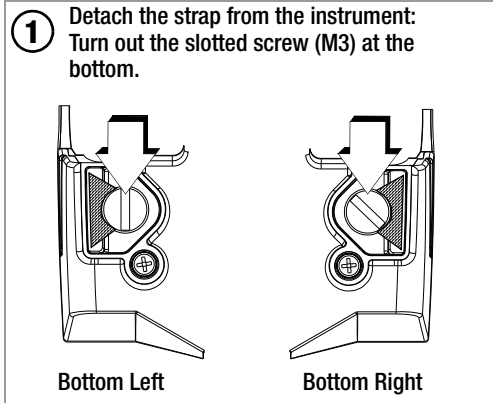

- ③ Feed the strap through from the front of the test instrument and secure it with the slotted screw (M3).

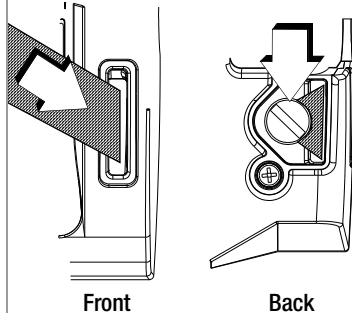

### 13.3 Technical Data for Measurement Cables (scope of delivery: KS17-4 safety cable set)

#### Electrical Safety

Maximum rated voltage	600 V	1000 V	1000 V
Measuring category	CAT IV	CAT III	CAT II
Max. rated current:	1 A	1 A	16 A
With safety cap attached	•	•	—
Without safety cap	—	—	•

#### Ambient Conditions (EN 61010-031)

Temperature	−20 °C ... + 50 °C
Relative humidity	Max. 80%
Pollution degree	2

#### Using the KS17-4



#### Attention!

Observe the instrument's maximum values for electrical safety. Measurements per DIN EN 61010-031 may only be performed in environments in accordance with measuring categories III and IV with the safety cap attached to the test probe at the end of the measurement cable.

In order to establish contact inside 4 mm jacks, the safety caps have to be removed by prying open the snap fastener with a pointed object (e.g. the other test probe).

### 13.4 Optional Accessories (not included)

#### ISO Calibrator 1 (material no. M662A)

Calibration adapter for testing the accuracy of instruments used for measuring insulation resistance and low-resistance for test voltages of up to 1000 V (per VDE 0413, parts 1, 2, 4 and 10).

#### KS-C

(material no. Z541F)

Cable set consisting of measurement cable and shielded high-resistance measurement cable for measurements in the G- $\Omega$  range

#### KS24

(material no. GTZ3201000R0001)

Cable set consisting of a 4 m long extension cable with a permanently attached test probe at one end and a contact protected socket at the other end, and 2 alligator clips which can be plugged onto the test probe

#### 1081 Probe (material no. GTZ3196000R0001)

Triangular probe for floor measurements per EN 1081, DIN VDE 0100-600 (standing surface insulation)

#### Z550A

(material no. Z550A)

Optional plug-on measurement cable with measurement key on the test probe and an additional key for illuminating the measuring point, including shielded, plug-in connector cable and test probe holder for attachment to the carrying strap.

## 14 Repair and Replacement Parts Service Calibration Center\* and Rental Instrument Service

If required please contact:

GMC-I Service GmbH  
**Service Center**

Thomas-Mann-Str. 20

90471 Nuremberg, Germany

Phone: +49 911 817718-0

Fax: +49 911 817718-253

e-mail [service@gossenmetrawatt.com](mailto:service@gossenmetrawatt.com)

[www.gmci-service.com](http://www.gmci-service.com)

This address is only valid in Germany. Please contact our representatives or subsidiaries for service in other countries.

\* **DAkkS calibration laboratory for electrical quantities, registration no. D-K-15080-01-01, accredited per DIN EN ISO/IEC 17025:2005**

Accredited quantities: direct voltage, direct current value, direct current resistance, alternating voltage, alternating current value, AC active power, AC apparent power, DC power, capacitance, frequency and temperature

## Competent Partner

GMC-I Messtechnik GmbH is certified in accordance with DIN EN ISO 9001:2008.

Our DAkkS calibration laboratory is accredited by the Deutsche Akkreditierungsstelle GmbH (national accreditation body for the Federal Republic of Germany) under registration number D-K-15080-01-01 in accordance with DIN EN ISO/IEC 17025:2005.

We offer a complete range of expertise in the field of metrology: from **test reports** and **factory calibration certificates** right on up to **DAkkS calibration certificates**.

Our spectrum of offerings is rounded out with free **test equipment management**.

An on-site **DAkkS calibration station** is an integral part of our service department. If errors are discovered during calibration, our specialized personnel are capable of completing repairs using original replacement parts.

As a full service calibration laboratory, we can calibrate instruments from other manufacturers as well.

## 15 Product Support

If required please contact:

GMC-I Messtechnik GmbH

### Product Support Hotline

Phone, +49 911 8602-0

Fax: +49 911 8602-709

e-mail: [support@gossenmetrawatt.com](mailto:support@gossenmetrawatt.com)

---

Edited in Germany • Subject to change without notice • PDF version available on the Internet